

69th Annual
Central Texas
Science and
Engineering Fair
2024-2025
Handbook

SECTIONS

1. Historical Information
2. Current Year
3. General Guidelines
4. Before You Begin
(Student Guidelines)

In association with:
International Science and Engineering Fair
Society for Science
Baylor University
McLennan Community College
Mayborn Museum Complex

TABLE OF CONTENTS

1. Historical Information

- Purpose / Board of Trustees 1
- Acknowledgements 2
- History 3
- Eligibility/Local Fairs 4
- Awards and Past Winners 5
- Past ISEF Finalists 9

2. Current Year

- Teacher Checklist 12
- Important Dates/Deadlines/Fees 13
- Tentative Schedule of Events 14
- Bryce C. Brown Award 15
- CTSEF Baylor University Scholarship 16

3. General Guidelines

- Rules for All Participants 17
- Ethics Statement 19
- Limitations/Continuation of Projects 20
- SRC Review Information 21
- Institutional Review Board Information 22
- Additional CTSEF Human Participants Guidelines 23
- Display and Safety Regulations 24
- Entry Rules/Judging Rules 28

4. Before You Begin

- Student Checklist 29
- Student Guidelines 31
- Guidelines for Hypotheses 35
- Adults Involved in a Science Project 36
- Category Descriptions 37
- Abstract Instructions 39
- Office Information 40

PURPOSE

The Central Texas Science and Engineering Fair, Inc. (CTSEF), in association with Society for Science, is a non-profit organization established under IRS guidelines. Its purpose is to promote interest and expertise in science and engineering among school students in a 13-county region. The CTSEF encourages and inspires students to explore and investigate their world through hands-on research.

After conducting research, students present their findings in three-dimensional exhibits that are evaluated by scientists and educators. Students acquire useful scientific knowledge as well as develop critical thinking and problem-solving skills that will help them now and in the future. At the competitions students have the opportunity to meet students from other schools, exchange ideas, and demonstrate the results of their research. Winners qualify to advance to state and international competitions.

CTSEF is governed by a board of volunteer trustees who work in close cooperation with administrative representatives of the Mayborn Museum Complex at Baylor University. Businesses, foundations, organizations, societies, and individuals help support the fair through community donations.

BOARD OF TRUSTEES

Officers

----- President
Ms. Rachel Hart, Controller

Emeritus Member

Mr. Calvin B. Smith

Members

Dr. Bradley Christian
Mr. Clint Detlefsen
Mr. Mike Green
Ms. Carol Lane
Ms. Kathy McMillan
Dr. Jonathan Miles
Dr. Kenneth Van Treuren
Mr. Charles Walter

Fair Co-Directors

Mrs. Linda Morris
Mr. David Lintz

Central Texas Science and Engineering Fair
One Bear Place #97154
Waco, Texas 76798

Baylor University
Mayborn Museum Complex
Email: science_fair@baylor.edu
Website: www.ctsef.org

Office

-----, Office Coordinator

ACKNOWLEDGEMENTS

We extend our sincere thanks to all who help make the Central Texas Science and Engineering Fair a success through grants, sponsorships, and donations of service, equipment, materials, and money.

SPONSORS

Baylor University

Mayborn Museum Complex

McLennan Community College

Waco Scottish Rite Bodies Charitable Foundation

Lee Lockwood Library and Museum

Waco Cardiology Associates

Radiation Technology Inc.

Society for Science

STEM Wizard

The CTSEF Board of Trustees

Red Men Museum and Library

Region 12 Education Service Center

Baylor University School of Education

HISTORY

The Texas Academy of Science made the first attempt to organize and promote a regional science fair in Central Texas in the mid-1950s with little success. It was late in 1956 that Baylor University became involved when the Baylor Chapter of The Society of the Sigma Xi provided the leadership to secure a regional science fair charter. Dr. Bryce C. Brown, who was a professor in the Biology Department and curator of the Strecker Museum, was named as director of the fair. Although the study of the sciences was not as emphasized in 1956 as it was to be after the USSR launched the first artificial Earth satellite, Sputnik, on October 4, 1956, Dr. Brown and his colleagues generated enough interest to get the fair started.

Baylor University and Sigma Xi sponsored the first fair on March 29, 1957. There were 40 entries from area schools in Bosque, McLennan, Navarro, Freestone, Limestone, Falls, Bell, Coryell, Somervell, and Lampasas counties. The winner in the exact science division was John Jeanes and the winners in the natural science division were Mary Ellen Rogers and Barbara Bruner. All three of the winning students were from Waco High School.

The fair was known as the District X Texas Science Fair and was affiliated with the National Science Fair. In 1964, the name was changed to the Central Texas Regional Science Fair. After 30 years of growth and expansion, the name was changed again, in 1994, to the Central Texas Science and Engineering Fair, Inc. (CTSEF).

The fair is now affiliated with the International Science and Engineering Fair (ISEF). The CTSEF is one of 15 regional fairs in the state of Texas. Finalists sent to the ISEF have won numerous awards over the past 68 years. Many of the students who have participated in earlier fairs have gone on to earn doctoral degrees in scientific fields. Some have returned to serve as sponsors, judges, and board members.

Calvin B. Smith succeeded Dr. Brown as director of the Strecker Museum and director of the fair in 1983. Mr. Smith passed the duties of director to A. Scott Lea, MD, president of Waco Infectious Disease Associates and McLennan County Public Health Director in 1994. Stephen C. Scott, owner of Sydaptic, Inc., followed Dr. Lea as director of the fair in 1998.

Following the resignation of Mr. Scott in 2013, Jeanne D. Waggener, R. Ph., Market Health and Wellness Director, WalMart Pharmacy, was elected as director of the fair. Under the leadership of Scott and Waggener, the long tradition of inspiring students to become involved in science and to develop interests that carry through into adulthood continued.

In 2016, Jeanne Waggener retired as director and board members Linda Morris and David Lintz were appointed as acting co-directors.

REGIONAL FAIR ELIGIBILITY

Any student in grades 6-12 enrolled in a public, private, parochial, military, or home school within the following counties is eligible to try for entry into the CTSEF: Bell, Bosque, Coryell, Falls, Freestone, Hamilton, Hill, Lampasas, Limestone, McLennan, Milam, Navarro, and Robertson.

ALL projects must have been approved for entry by the CTSEF through STEM Wizard prior to the local school fair. Winning at the local level guarantees only that a student is *eligible to apply for entry* in the CTSEF.

Only current year forms and applications are used to determine eligibility of and participation by a student researcher.

The project submitted to the CTSEF must be the student's own work. It is the student's responsibility to check with the CTSEF for any additional restrictions or requirements.

CTSEF may certify up to the top three entries from each category of the junior division and senior division to enter state competition. Two Senior Division Finalists may be certified for international competition. Students must meet all ISEF rules and guidelines and not be over 21 years of age by May 1 of the fair year.

The CTSEF is under contract with Society for Science and the Regeneron International Science and Engineering Fair (ISEF) to conduct the regional fair according to the rules and guidelines that ISEF has set. **Participants must observe all the rules in this handbook.** Ignorance of these rules will not excuse anyone from meeting the entry requirements. The purpose of these rules is to provide basic guidance and to protect students, teachers, and parents, as well as human participants and animal subjects.

GENERAL GUIDELINES FOR LOCAL SCHOOL FAIRS

ALL projects expecting to advance to the regional fair must be approved by the CTSEF prior to experimentation and entry in any local fair.

To be approved, a student must follow the rules and guidelines (CTSEF and ISEF) located on the CTSEF website: www.ctsef.org

Student participants will need to complete the online approval process (STEM Wizard) to be eligible. However, this does not guarantee that a student may enter the CTSEF.

Displays, classroom demonstrations, or poster exhibits showing only library research are not acceptable. Projects must present the results of experimental investigation or field studies that include data gathering and analysis, or engineering-based projects. Projects that use only models or demonstrations are not allowed.

NO simple product testing projects are allowed at the Regional Fair level. Although perhaps acceptable at the local level, basic product testing projects may not advance to the CTSEF.

A student must first enter, participate in, and be judged in a local school fair to be considered for the regional fair competition.

Participation in a local fair and placing **1st, 2nd, or 3rd** in one of the **21 categories**, will make a student eligible to enter the Regional Fair (CTSEF) in Junior Division (6th - 8th grades) or Senior Division (9th - 12th grades). Your local school fair may enter only the 1st, 2nd, or 3rd place winner, regardless of grade, in one of the 21 categories. [Example: A school may enter only the top 1st, 2nd, or 3rd place per fair, per category, per school.] **NOT** accepted for entry: 1st, 2nd, or 3rd place winners per school grade.

AWARDS

REGULAR AWARDS

A certificate of merit may be awarded to each exhibitor at his or her exhibit.

Regular awards consist of a 1st, 2nd, 3rd place, and/or Honorable Mentions in each of the 21 senior categories as well as 1st, 2nd, 3rd place and/or Honorable Mentions in each of the 21 junior categories. Not all places may be awarded each year.

SPECIAL AWARDS

Special Awards are presented by many local, regional, and national organizations. These awards often include certificates, cash, plaques, books, subscriptions, medallions, savings bonds, trophies, T-shirts, etc.

Special Awards judges may or may not use a similar scoring method as the regular judges since the nature and purpose of special awards varies from organization to organization. Students may or may not be interviewed, depending on each individual organization.

The following organizations have presented awards in the past:

1519 Surveying and Engineering	Health Physics Society - South Texas Chapter
American Association of University Women – Waco Branch	Heart of Texas Counseling Association
American Meteorological Society	Hillcrest Baptist Medical Center
Association for Women Geoscientists Foundation	Heart of Texas Society of Health System Pharmacists
Baylor University: Baylor University Scholarship	Keep Waco Beautiful, Inc.
Mayborn Museum Complex	Mathnasium
School of Education	McLennan County Medical Society
Thermo Fisher Scientific JIC	National Council of Teachers of Mathematics
Cameron Park Zoo	Renewable Aviation Fuels Development Center
Central Texas Audubon Society	Society for In Vitro Biology
Central Texas Chapter, Texas Society of Professional Engineers	Texas A&M Agrilife Extension
Central Texas Dental Society	Texas American Water Works Association – Central Texas Chapter
City of Waco Solid Waste Department	United States Air Force
Central Texas Audubon Society	United States Dept. of Health & Human Services
CP&Y	United States Metric Association
Domelsmith Consumer Award	United States Navy and Marine Corps
Entomological Society of America - Southwest Branch	Water Environment Association of Texas
Garden Patch Garden Club	Yale Science and Engineering Association

THE BRYCE C. BROWN AWARD

Each year, in memory of Dr. Bryce C. Brown, the CTSEF founder and first director, an award is given to the most promising young scientist, regardless of age or category. Only ONE STUDENT FROM EACH SCHOOL is eligible to qualify for this award each year. Nominees must be recommended by their school science teacher after demonstrating their proficiency and interest in the scientific method.

This award is one of the most prestigious offered by the CTSEF. Nominees demonstrate both a continuing interest in science or engineering and the intent to pursue a science-related career. The Bryce C. Brown Award will not be awarded more than once to the same student.

Past winners are:

1984	Alan Gilchrest	7 th	Robinson Jr. High	Environmental Science
1985	Matthew Mladenka	8 th	Wiley Middle	Behavioral & Social Sciences
1986	Norman Y. Ho	11 th	Ellison High	Biochemistry
1987	Zach Coombs	12 th	Waco High	Engineering
1988 (tie)	Chia Ming Wang	12 th	Waco High	Microbiology
1988 (tie)	Rene Drummond	12 th	Rockdale High	Behavioral & Social Sciences
1989	Dawn Landua	8 th	Midway Jr. High	Behavioral & Social Sciences
1990	K. Layne Gossett	12 th	Rockdale High	Medicine & Health
1991	Hayley Voige	10 th	Waco High	Behavioral & Social Sciences
1992 (tie)	Kelly W. Gossett	11 th	Rockdale High	Engineering
1992 (tie)	Kevin W. Stafford	12 th	Troy High	Earth & Space Science
1993	Jay T. Sartain	9 th	Midway High	Behavioral & Social Sciences
1994	Peter Crossno	12 th	Rockdale High	Microbiology
1995	Matt Ferguson	12 th	Rockdale High	Zoology
1996	Melissa Baumann	8 th	O. J. Thomas Jr. High	Microbiology
1997	Alicia Willson	10 th	Robinson High	Microbiology
1998	Steven Sielaff	12 th	Robinson High	Earth & Space Science
1999	JonCee Kelley	12 th	C. H. Yoe High	Environmental Science
2000	Bennett Lane	8 th	Midway Middle	Behavioral & Social Sciences
2001	Timothy Hartland	8 th	Midway Middle	Engineering
2002	Laura A. Hartman	11 th	China Spring High	Microbiology
2003	David Martin	8 th	St. Louis School	Microbiology
2004	Lindsay Liles	10 th	C. H. Yoe High	Microbiology
2005	Amanda Hartman	12 th	China Spring High	Microbiology
2006	Tara Gloyna	11 th	Temple High	Environmental Science
2007	Hannah Davis	12 th	C. H. Yoe High	Behavioral & Social Sciences
2008	Sandy Ren	9 th	Midway High	Team Category
2009	Logan Kostroun	12 th	C. H. Yoe High	Plant Sciences
2010	Julia McKnight	8 th	Midway Middle	Behavioral & Social Sciences
2011	Linda Ren	9 th	Midway High	Biochemistry
2012	Camille Roberts	8 th	Midway Middle	Behavioral & Social Sciences
2013	Edward Kim	8 th	Midway Middle	Energy/Transportation
2014	Alana B. Armstrong	8 th	Waco Baptist Academy	Environmental Management
2015	Caroline Kutach	12 th	Midway High	Animal Science
2016				
2017	Codi McMillan	8 th	Midway Middle	Biomedical and Health Sciences
2018	Samuel Taylor Johnson	8 th	Classical Conversations School	Physics & Astronomy
2019	Sophie Kearney	11 th	Midway High School	Microbiology
2020	Hope Tucker	12 th	Live Oak Classical School	Earth and Environmental Sciences

2021				
2022	Madeleine Mack	8th	China Spring Middle School	Microbiology
2023	Kaylee George	12th	McGregor High School	Plant Sciences
2024	Gracelynn Singer	9th	McGregor High School	Animal Sciences

BAYLOR UNIVERSITY SCHOLARSHIP AWARD

Students in their junior or senior year of high school who have qualified for entry in any category in the Central Texas Science and Engineering Fair may apply for the Baylor University Scholarship. The first scholarship award provided \$1000 tuition to Baylor University. This amount was increased to \$2000 beginning in 2006. This amount was then increased to \$4000 beginning in 2011.

Past winners are:

1998	Steven Sielaff	12 th	Robinson High	Earth & Space Science
1999	Nina Hathi	12 th	Robinson High	Mathematics
2000	Kyle Conklin	11 th	C. H. Yoe High	Botany
2001	Erica Maresh	10 th	Mexia High	Chemistry
2002	Laura A. Hartman	11 th	China Spring High	Microbiology
2002	Jared Locklear	12 th	C. H. Yoe High	Environmental Science
2003	Laura A. Hartman	11 th	China Spring High	Microbiology
2004	Amanda Hartman	11 th	China Spring High	Microbiology
2005	John Hertenberger	11 th	C. H. Yoe High	Environmental Science
2006	Haley N. Wasson	12 th	Ellison High	Biochemistry
2007	Stephanie Simcox	11 th	McGregor High	Cellular and Molecular
2008	Stephanie Simcox	12 th	McGregor High	Cellular and Molecular
2009	Kristen Kylberg	12 th	Temple High	Team Category
2010	Not awarded			
2011	Not awarded			
2012	Not awarded			
2013	Nicholas St. John	12 th	Whitney High	Chemistry
2014	Lauren Strickland	11 th	Central High	Biochemistry
2015	Not awarded			
2016	Not awarded			
2017	Not awarded			
2018	Not awarded			
2019	Sophie Kearney	11 th	Midway High	Microbiology
2020	Not awarded			
2021	Not awarded			
2022	John Olafsen	11 th	Live Oak Classical	Robotics & Intelligent Machines
2023	Not awarded			

THERMO FISHER SCIENTIFIC JIC AWARD

Society for Science and Thermo Fisher Scientific (previously Broadcom MASTERS) sponsor the Thermo Fisher Junior Innovators Challenge — the nation’s premier STEM competition for middle school students. Only the top 10 percent of 6th, 7th and 8th grade projects entered in Society-affiliated fairs around the country are eligible to apply. Thirty finalists are chosen and compete in a virtual competition, participating in team challenges in addition to being judged on their science research projects.

Thermo Fisher also recognizes finalists’ science teachers with a one-year classroom subscription to *Science News* magazine and awards the finalists’ schools with \$1,000 each to use toward STEM activities.

Past winners are:

2021	Gabriela Guerra Sanchez	7th	Tennyson Middle School	Top 30 Finalist in the nation
2022				
2023				
2024				

PAST ISEF FINALISTS

1957	Mary Ellen Rogers John Jeanes Barbara Bruner	Waco High Waco High Waco High	1978	Michael S. Wren 4th - Grand Award - ISEF Earth & Space Science Marina Hsieh	Killeen High Richfield High
1958	Julian Sewell Elizabeth Janeway	Belton High University High	1979	David Schechter 3rd - Grand Award - ISEF Biochemistry Felicia K. Park	Richfield High Richfield High
1959	Estelle Jares John Fitzpatrick	West High Marshall High	1980	Bill Richter 4th - Grand Award - ISEF Earth & Space Science 2nd - U.S. Air Force Tamara Hebert	West High Rockdale High
1960	Gerald Birdwell Jim Brocker	Eagle Lake High Temple High	1981	Colin Valentine Ronald Rummel	Rockdale High Yoe High
1961	Jim Brocker Gabriele Luthardt	Temple High Killeen High	1982	----- Tamara Hebert Honorable Mention - Eastman Kodak Co. Honorable Mention - USAF	Richfield High Rockdale High
1962	Bart Reilly Edward Erwin	Corsicana High Corsicana High	1983	David Boutwell 2nd - Grand Award - ISEF Environmental Sciences 2nd - American Society of Civil Engineers 2nd - U.S. Navy 5th - American Association of Petroleum Engineers John Ho	Richfield High Rockdale High Yoe High
1963	Bobby Fauvelle Stephen Tuttle	Corsicana High Temple High			Ellison High
1964	Ken Smith Connie Bullock	University High Hico High	1984	Chia-Ying Wang Russell Yakesch	Richfield High Rockdale High
1965	Jeff Bentley Jan Flowers	Temple High Richfield High	1985	Kerry Sagebiel Honorable Mention - Eastman Kodak Co. Chia-Ying Wang	Rockdale High Richfield High
1966	Jeff Bentley Barbara Jackson	Temple High Killeen High	1986	Kerry Sagebiel 3rd - Grand Award - ISEF Earth & Space Science Honorable Mention - Eastman Kodak Co. Norman Ho	Rockdale High Ellison High
1967	Lisle Posey Cynthia Torrance	Mexia High Waco High	1987	Kerry Sagebiel Rene Drummond	Rockdale High Rockdale High
1968	Wilson Erwin William Brown	Corsicana High Lampasas High	1988	Rene Drummond Chia-Ming Wang Honorable Mention - Eastman Kodak Co.	Rockdale High Waco High
1969	James Harper Patrick Gibson	Copperas Cove High Corsicana High	1989	Michael Sterling	Waco High
1970	John Hawk Patrick Gibson	Corsicana High Corsicana High	1990	Layne Gossett 2nd - Grand Award - ISEF Medicine & Health 1st - Eastman Kodak Co. 3rd - Optical Society of America 3rd - Society of Photographic Scientists/Engineering	Rockdale High
1971	James Nance Donald Parker	Yoe High Copperas Cove High	1990	Danny Drummond 1st - Eastman Kodak Co.	Rockdale High
1972	Steve Shehorn Donald Parker	Robinson High Copperas Cove High			
1973	William Duncan Gary Fuchs	Copperas Cove High Yoe High			
1974	Gary Fuchs David Hollas	Yoe High Yoe High			
1975	Newton D. Farrar William S. Smith	Hico High Richfield High			
1976	Dana Snipes Philip Frederick	Groesbeck High Tennyson Jr. High			
1977	Brian Linver Gary Frenzel	Killeen High Tennyson Jr. High			

	2nd - Society of Photographic Scientists/Engineering		Amanda Hartman	China Spring High 4th ISEF Grand Award - Microbiology
1991	Danny Drummond 4th - Grand Award - ISEF Earth & Space Science 1st - Eastman Kodak Co. 1st - U.S. Navy Earth & Space Sciences Honorable Mention - NASA	Rockdale High	2003 Team: Sarah May, Karianne Wood	Mexia High
	Kevin Stafford	Troy High	Amanda Hartman	China Spring High
1992	Danny Drummond 3rd - Grand Award - ISEF Earth & Space Science 3rd - Eastman Kodak Co,	Rockdale High	2004 Amanda Hartman	China Spring High
	Kevin Stafford	Troy High	4th ISEF Grand Award - Microbiology Florida Institute of Technology Scholarship Oregon State University Scholarship	
	4th - Grand Award - ISEF Earth & Space Science Merit - Society of Exploration Geophysicists Honorable Mention – Society for Mining, Metallurgy, & Exploration		Tara Gloyna	Temple High
1993	Danny Drummond Eastman Kodak Award U.S. Marine Corps Office of Naval Research and Scholarship Award	Rockdale High	2005 Tara Gloyna	Temple High
	Erica Phillips	Rockdale High	2nd ISEF Grand Award - Environmental Science Society of Environment Toxicology & Chemistry Award	
1994	Jay Sartain 4th - Grand Award - ISEF Behavioral & Social Sciences 1st - U.S. Air Force	Midway High	Lindsay Liles	Yoe High
1995	Jay Sartain Honorable Mention - Association for Behavioral Analysis	Midway High	2006 Tara Gloyna	Temple High
	Matt Ferguson	Rockdale High	3rd ISEF Grand Award - Environmental Science Society of Environment Toxicology & Chemistry Award	
	Team: Robin Melcher, Candice Diver, Rhya Taylor	Rockdale High	Lindsay Liles	Yoe High
1996	Jay Sartain 3rd - Grand Award - ISEF Behavioral & Social Sciences	Midway High	2007 Tara Gloyna	Temple High
	Teri Burgett	Rockdale High	2nd ISEF Grand Award - Environmental Science U.S. Air Force Award	
	Team: Kevin Kelly, Kyle Gibson		Stephanie Simcox	McGregor High
1997	Deanne Masur Sondra Beissner Honorable Mention-Eastman Kodak Co. Team: Julie Burns, Jenny Gebhart	Rockdale High Temple High Rockdale High	2008 Stephanie Simcox	McGregor High
			Logan Kostroun	Yoe High
1998	Steven Sielaff 1st - U.S. Air Force	Robinson High	2009 Logan Kostroun	Yoe High
	JonCee Kelley	Yoe High	3rd ISEF Grand Award – Plant Sciences Claire Gamino	Temple High
1999	Alicia Willson Melissa Baumann	Robinson High Yoe High	Team: Kristen Kylberg, Shereen Rabie, Areej Rabie	Temple High
2000	Melissa Baumann Kyle Conklin	Yoe High Yoe High	2010 Nisha Pillai	Temple High
2001	Stephanie Gelner Lacey Vaculin Honorable Mention Endocrine Society	Yoe High Yoe High	Sandy Ren	Midway High
2002	Jeffrey Easterwood	Rockdale High	Florida Institute of Technology Scholarship	
			2011 Jack Rhoades	Yoe High
			Nisha Pillai	Temple High
			2012 Iyan Younus	Yoe High
			Devin Buchanan	Yoe High
			2013 Thomas Tow	Yoe High
			Linda Ren	Midway High
			2014 Lauren Strickland	Central High
			Darin Garrett	Harker Heights High
			2015 Edward Kim	Midway High
			4th ISEF Grand Award - Biochemistry Lauren Willey	Yoe High
			2016 Edward Kim	Midway High
			1 st ISEF Grand Award - Biochemistry Lauren Willey	Yoe High
			2017 Edward Kim	Midway High
			Neeraj Bhakta	Yoe High
			2018 Remi Labeille	Midway High

1st ISEF Grand Award – Energy: Chemical
Caleb Chakmakjian Live Oak Classical

2019 Sophie Kearney Midway High
3rd ISEF Grand Award - Microbiology
Team: Caleb Chakmakjian,
Wyatt Tyson Live Oak Classical

2020 Team: John Singer, Kaylee George
 McGregor High
Ezra Stegemoller Classical Conversations
 School - Waco

2021 Team: Caleb Chakmakjian, John Lewis
 Live Oak Classical
1st - Aerojet Rocketdyne Foundation
Raytheon Technologies Corp Award

2022 Maddie Kirclin Live Oak Classical
Miriam Carl Live Oak Classical

2023 Abigail Olmstead Greater Waco Christian
 Home Educators

2024 David Martinez China Spring High
Madeleine Mack China Spring High

TEACHER CHECKLIST

- READ:** Pay particular attention to and study this handbook thoroughly and carefully.
- SUBMIT BY PRE-APPROVAL DEADLINE:**
 - ◆ Required forms and paperwork
Every student and his/her parent must complete and submit online a **Waiver and Release of Liability Form** from Baylor for CTSEF to process his/her paperwork.
 - ◆ \$5 Filing Fee per student for pre-approval
All research projects: The research plan and all applicable forms must be completed online with a filing fee for each student before the pre-approval deadline (see “Important Dates and Deadlines”). Students progressing to the CTSEF may elect to pay both filing fee and entry fee at the same time after the CTSEF.
- ADDRESS DEFICIENCIES AND RESUBMIT BY CORRECTION DEADLINE:**
 - ◆ Deficiency
A deficiency summary for any corrections will be returned to you online to your student’s account.
 - ◆ Paperwork must be properly resubmitted online
The student and teacher must read each comment. After corrections are made, return the corrected project to the CTSEF for a second review online to STEM Wizard. All online paperwork is required to be returned until the online process is complete. Once this process is complete you will be instructed to make a copy of everything that the reviewers have reviewed (online) and approved. This is the students’ final review for approval and signature from the CTSEF committee chair.
A student’s project is approved to begin experimentation ONLY when the committee chairperson has signed the Approval Form (1B).
- SUBMIT BY ENTRY DEADLINE:**
 - ◆ Official Entry
All entries must be submitted online in STEM Wizard to compete at the CTSEF.
Only the 1st, 2nd, and 3rd place winners in each category may enter the CTSEF from the local school science fair in junior (6-8 grades), and senior division (9-12 grades).
 - ◆ All approved and necessary forms, **plus a \$12 entry fee per student.**
LATE APPLICANTS WILL NOT BE ACCEPTED FOR ENTRY.
No last-minute changes will be made at the fair for inaccurate information submitted.
Entry fees will not be refunded if a student fails to enter the CTSEF. No exceptions.
 - ◆ Applications for the Bryce C. Brown Award and Baylor University Scholarship Award (if applicable).
- REGISTER STUDENTS** at the regional fair site between 10:00 and 12:00 a.m. on Tuesday.
- ATTEND** the Teacher/Sponsor Meeting at 6:15 p.m. on Tuesday evening.
- PLAN** for late judging on Tuesday evening. Dismissal of students will be no later than 9:30 p.m.
- ATTEND** the Awards Ceremony on Wednesday (times may vary).

IMPORTANT DATES AND DEADLINES

Regional Science Fair (CTSEF)

Texas Science and Engineering Fair (TXSEF)

International Science Fair (ISEF)

February 11-12, 2025

March 28-29, 2025 (College Station)

May 10-16, 2025 (Columbus, OH)

DEADLINES:

PRE-APPROVAL: All paperwork must be received online as soon as it is completed. The last deadline date to submit any new projects for first review is January 17, 2025.

Final Corrections Completed and Submitted
BRYCE C. BROWN AWARD APPLICATION
BU SCHOLARSHIP AWARD APPLICATION

Friday, January 20, 2025
Friday, February 7, 2025
Friday, February 7, 2025

IRB Interviews:

Regional IRB interviews may be required of students and will be conducted monthly. This will occur only if the IRB committee requests an interview and the student has an assigned interview time. It is the responsibility of the Teacher/Sponsor or student/s to contact the CTSEF office to schedule the interview. Students are required to attend the interview with a copy of their online submitted paperwork. The location and starting time of the IRB interview will be emailed to the Teacher/Sponsor and student/s. In some cases, a telephone interview can be scheduled with the IRB committee.

Additional review dates may be scheduled if needed and will include the months of December and January.

The date for the interview will be scheduled only after the IRB committee requests an interview. If no interview is requested, no interview is required.

FEES

Filing Fee for Pre-Approval/Review:

\$ 5 per student

Entry Fee:

\$12 per student

Each student submitting his/her paperwork for CTSEF approval before experimentation must pay a \$5 filing fee per student. This covers any number of needed reviews up to final submittal date.

Each student entering the CTSEF must pay a \$12 entry fee.

There will be no refunds for any fees.

TENTATIVE SCHEDULE OF EVENTS

All fair activities will take place at the Lee Lockwood Library and Museum.

Tuesday - February 11, 2025

- 10:00 - 12:00 a.m. Registration and exhibit setup – Lower Atrium and Howard Ballroom
- 10:00 - 12:00 a.m. Display & Safety Committee inspections, SRC reviews and appeals
- 12:00 - 1:00 p.m. Lunch for students – on your own
- 1:30 - 3:30 p.m. Junior Science Quiz Bowl – Auditorium
- 3:15 - 6:15 p.m. Special Awards judging (students may be present at their projects)
- 3:30 - 5:00 p.m. Interviews - Bryce C. Brown Award, BU Scholarship – TBD
- 5:00 - 5:45 p.m. Dinner for students – Lower Atrium (ticket required)
- 5:00 - 6:00 p.m. Regional Judges' orientation and dinner– Library
- 6:00 - 9:00 p.m. REGIONAL JUDGING – Howard Ballroom
All exhibitors must be with their displays until released
- 6:15 - 7:30 p.m. Teacher/Sponsors dinner - Library

Wednesday - February 12, 2025

- 8:30 - 11:30 a.m. FAIR OPEN TO PUBLIC – Howard Ballroom
- 9:00 - 11:00 a.m. Awards Ceremony- Auditorium
- 11:00 - 11:30 a.m. Winner's orientation for TXSEF & ISEF - Auditorium
- 11:30 a.m. Exhibit removal

Projects placing 1st or second in each category MUST remain on exhibit for 20 minutes following the end of the Awards Ceremony to allow others an opportunity to view the winning projects.

No projects will be disassembled before 11:30 a.m. to allow full viewing time by the visiting public.

THE BRYCE C. BROWN AWARD

Each year, in memory of Dr. Bryce C. Brown, the CTSEF founder and Director from 1956–1983, an award is given to the most promising young scientist regardless of age or category. Only ONE NOMINEE FROM EACH SCHOOL is eligible to qualify for this award each year. The Nominee must be recommended by his/her school science fair teacher, after demonstrating proficiency and interest in the scientific method.

This award is one of the most prestigious offered by the CTSEF. Nominees should demonstrate both a continuing interest in science or engineering, and intent to pursue a science-related career. The Bryce C. Brown Award will not be awarded more than once to the same student.

Application Procedure:

- The science teacher/sponsor should complete the application form and letter of recommendation, place in one envelope, and mail or deliver it to the Central Texas Science and Engineering Fair office. The documents may also be scanned and emailed to science_fair@baylor.edu. Please ensure that the scanned documents are legible.
- The completed application must be in the CTSEF office by February 7, 2025.
- Applications for the Bryce C. Brown Award for the Most Promising Young Scientist will be screened by a panel of Baylor faculty and CTSEF Board Members. The applicants will be invited to an interview with the panel during the Regional Science Fair on Tuesday February xx, 2025. The names of students who will be interviewed will be posted at registration.
- The Bryce C. Brown Award recipient will be announced at the annual CTSEF awards ceremony.

CTSEF BAYLOR UNIVERSITY SCHOLARSHIP

Students in their **junior** or **senior** year of high school who have qualified for entry in any category in the 2025 Central Texas Science and Engineering Fair may apply for the CTSEF Baylor University Scholarship award. The scholarship provides **\$4,000** tuition to Baylor University.

Application Procedure:

- The student should complete the application form and mail or deliver it with two letters of recommendation and a writing sample—all in one envelope—to Central Texas Science and Engineering Fair office. The documents may also be scanned and emailed to science_fair@baylor.edu. Please ensure that the scanned documents are legible.

The application and accompanying materials must be in the CTSEF office by February 7, 2025.

- Applications for the scholarship will be screened by a panel of Baylor faculty, and the top three applicants will be invited to an interview with the scholarship selection committee during the Regional Science Fair on Tuesday February xx, 2025. The students who will be interviewed will be notified at registration. Time and place of the interview will be included.
- The scholarship recipient will be announced at the annual CTSEF Awards Ceremony Wednesday, February xx, 2025.
- In addition to the information on the application form, the selection committee will consider:
 1. The applicant's academic record in high school.
 2. Recommendations written by his/her Science Fair sponsor and high school principal or counselor.
 3. He/she should demonstrate interest in becoming a Baylor University student.

Scholarship Information:

- The Baylor University Scholarship application form will be sent in January.
- The \$4,000 scholarship is limited to tuition remission only and does not cover books, housing, or fees.
- The student must meet all the qualifications necessary to be accepted into Baylor, must apply for admission to Baylor through regular procedures, must be accepted into Baylor, and must register for Baylor classes before the scholarship goes into effect.
- The student should report receipt of the scholarship in any application for a financial aid package at Baylor University.

The signed application must be accompanied by:

- 1) **Letters of recommendation** from:
 - a. your Science Fair sponsor
 - b. your high school principal or high school counselor

These letters should explain your eligibility for the scholarship based on the above criteria and should include any other information about your qualifications for the award.
- 2) A **writing sample**, in which you explain:
 - a. ways you think participation in the Science Fair program benefits students
 - b. your reasons for wanting to attend Baylor University

The writing sample may be typewritten or neatly handwritten, but it should not exceed one-page in length (if typewritten) and should contain at least 150 words, but not more than 300 words.

Send application, letters of recommendation, and writing sample in one envelope, or electronically, to:
BU Scholarship
Central Texas Science & Engineering Fair
One Bear Place #97154
Waco TX 76798

Deadline: February 7, 2025 by 5:00 p.m.

RULES FOR ALL PARTICIPANTS

- 1) Students must participate and place 1st, 2nd, or 3rd in one of the 21 categories in a local fair and meet all the criteria set out in the handbook.
- 2) All CTSEF and ISEF rules and guidelines must be read, understood, and followed.
- 3) To compete in the CTSEF, every student must complete the **Waiver and Release of Liability Forms, Student Checklist (1A), Research Plan, and Approval Form (1B)**, and review with his/her teacher or Adult Sponsor as teacher/sponsor completes the **Checklist for Adult Sponsor (1)**.
- 4) Projects must adhere to all Federal, State, and local laws and regulations.
- 5) Students should retain all original forms. These forms will always include at least the **Checklist for Adult Sponsor (1), Student Checklist (1A), Research Plan, and Approval Form (1B)**.
- 6) Certain projects require additional forms and/or specific reviews.
 - A) All projects involving human participants require special procedures.
 - a) An Institutional Review Board (IRB) must review project and approve BEFORE experimentation begins.
 - b) **Human Participants Form (4)** is required for all projects involving human participants. You may need an Informed Consent Form as well. An Informed Consent Form is used to provide information to the research subject (or parent/guardian) and to document written informed consent, minor assent, and/or parental permission.
 - c) A copy of any test, survey, or questionnaire must be provided for parental review for subjects less than 18 years of age.
 - d) If a school chooses to have a local Institutional Review Board (IRB) the student must have an interview with that board.
 - e) After the local IRB review board has approved the student's project the student must submit the project to the CTSEF for approval.
 - f) The CTSEF IRB will review all human participants projects.
 - g) If there are deficiencies or changes that need to be addressed, the corrections must be made and then re-uploaded to the student's profile online. Return the project to review status, by the next deadline time. This must be before the IRB interview (if one is requested).
 - h) If the project corrections are not made, there will be no other review until you have completed the corrections listed.
 - i) If an IRB interview is requested, the student /teacher/sponsor must email or call the CTSEF office to set an appointment time. The student needs to make sure to attend their scheduled interview time and bring a clean, corrected copy of the research plan and all forms.
 - B) Experiments that involve vertebrate animals, potentially hazardous biological agents, controlled substances, nonexempt recombinant DNA, certain tissue studies, and all studies involving more than a minimal risk to the researcher, require approval from a Scientific Review Committee (SRC) **before** experimentation begins and must be submitted using the online process (www.ctsef.org) [read **Research Plan instruction sheet**].
 - C) All other projects require a review by the CTSEF and must be submitted online.

- 7) All studies involving vertebrate animals, potentially hazardous biological agents, controlled substances, nonexempt recombinant DNA, certain tissue studies, and all studies involving more than a minimal risk in human participants must have a Direct Supervisor or Qualified Scientist, depending on risk assessment.
- 8) Projects that are continuations of previous years' work and that require IRB/SRC approval must be re-approved prior to experimentation for the current year. Any continuing project must document new or more advanced research.
- 9) **Human and Vertebrate Animal Tissue Form (6B)**, if applicable, must be submitted for SRC review and approval before student begins experimentation.
- 10) The use of alcohol, acid rain, insecticides, herbicides, and heavy metals in toxicity or behavioral studies on live vertebrates is prohibited.
- 11) Studies involving any pathogenic or potentially pathogenic agents are prohibited in a home environment, but specimens may be collected at home.
- 12) Non-invasive (behavioral) studies involving pets and livestock may be done at home.
- 13) **No vertebrate animal deaths** due to the experimental procedures are permitted in any group or subgroup. Such a project will fail to qualify for competition.
- 14) Any proposed changes in the **Research Plan** by the student after initial IRB/SRC approval must have subsequent IRB/SRC approval before experimentation begins/resumes.
- 15) If work was conducted in an institutional or industrial setting any time during the current project year, **Regulated Research Institutional/Industrial Setting Form (1C)** must be completed.
- 16) Use of models alone or demonstrations is not creative and is not allowed.
- 17) Collections should only be used to support an investigation or help to answer a question.
- 18) Display or poster exhibits showing only library research are **not acceptable**. Projects must present the results of experimental investigation or field studies.
- 19) NO product testing is allowed at the Regional Fair level. Although acceptable at the local level, product testing projects may not advance to the CTSEF.
- 20) Each student may enter only **one** project that covers research done over a maximum continuous 12-month period between January of previous fair year and current year fair.
- 21) All exhibits must adhere to CTSEF/ISEF safety and size requirements.
- 22) **It is important that students make a copy of all original signed forms.**
- 23) It is the student's responsibility to check with the CTSEF for any additional restrictions or requirements.

ISEF and CTSEF ETHICS STATEMENT

Student researchers, as well as adults who have a role in their projects, are expected to maintain the highest ethical standards. These standards include, but are not limited to:

- **Integrity.** Honesty, objectivity, and avoidance of conflicts of interest are expected during every phase of the project. The project should reflect independent research done by the student(s) and presented in their own words with proper citation, most particularly if artificial intelligence is used. The project may only represent one year of work and must not include fraudulent data, plagiarism, or inappropriate use of AI in presenting work that is not their own.
- **Legality.** Compliance with all federal, state, and local laws and regulations is essential. In addition, projects conducted outside the U.S. must also adhere to the laws of the country and jurisdiction in which the project was performed. All projects must be approved by a Scientific Review Committee (SRC), and when necessary, must also be approved by an Institutional Review Board (IRB), Institutional Animal Care and Use Committee (IACUC), and/or Institutional Biosafety Committee (IBC). It is recommended that students reference their local, state, or national laws and regulations.
- **Respect for Confidentiality and Intellectual Property.** Confidential communications, as well as patents, copyrights, and other forms of intellectual property must be honored. Unpublished data, methods, or results may not be used without permission, and credit must be given for all contributions to the research.
- **Stewardship of the Environment.** It is the responsibility of the researcher and the adults involved to protect the environment from harm. Introduction or disposal of native, genetically-altered, and/or invasive species, (e.g. insects, plants, invertebrates, vertebrates), pathogens, toxic chemicals or foreign substances into the environment is prohibited. It is recommended that students reference their local, state, or national regulations and quarantine lists.
- **Acknowledgment of Risks.** All projects involve some amount of risk. Everyone is expected to recognize the hazards, assess the risks, minimize the risks, and prepare for emergencies.
- **Animal Care.** Proper care and respect must be given to vertebrate animals. The use of non-animal research methods and alternatives to animal research are strongly encouraged and must be explored before conducting a vertebrate animal project. The guiding principles for the use of animals in research includes the following “Four R’s: Replace, Reduce, Refine, Respect.
- **Human Participant Protection.** The highest priority is the health and well-being of the student researcher(s) and human participants.
- **Potentially Hazardous Biological Agents (PHBAs).** It is the responsibility of the student and adults involved in the project to conduct and document a risk assessment, and to safely handle and dispose of organisms and materials.

ALL PROJECTS. Scientific fraud and misconduct are not condoned at any level of research or competition. This includes plagiarism, forgery, use or presentation of other researcher’s work as one’s own and fabrication of data. Fraudulent projects will fail to qualify for competition in affiliated fairs and ISEF. Society for Science reserves the right to revoke recognition of a project subsequently found to have been fraudulent.

LIMITATIONS FOR ISEF

1. Each student may enter only one project, which covers research done over a maximum continuous 12-month period between January 2024 and May 2025.
2. Students may compete in only one ISEF Affiliated Fair, except when proceeding to a state/national fair affiliated with the ISEF from an affiliated regional fair.
3. Any student in grades 9-12 or equivalent is eligible, none of whom having reached the age of 21 on or before May 1 preceding the ISEF.

CONTINUATION OF PROJECTS

1. **Students will** be judged only on the most recent year's research. Display boards must reflect the current year's work only. However, supporting data books (not research papers) from previous related research may be exhibited on the table, properly labeled as such. The project title displayed in the participant's area may mention years (for example, "Year Two of an Ongoing Study"). This project year includes research conducted over a maximum of 12 continuous months from January of one year to May the following year. Any continuing project must document new and different research (e.g., testing new variables or new line of investigation, etc.). Repetition of previous experimentation or increasing sample sizes are examples of unacceptable continuations.
2. **Longitudinal studies are permitted as an acceptable continuation under the following conditions:**
 - a) The study is a multi-year study testing or documenting the same variables in which time is the critical variable. Example: Effect of high rain or drought on soil in a given basin or return of flora and fauna in a burned period over time.
 - b) Each consecutive year must demonstrate time-based changes.
 - c) The display board must be based on collective past conclusionary data and its comparison to the current year data set. No raw data from previous years may be displayed.
3. Complete the **Continuation Projects Form (7)**. Documentation must include the **previous year's abstract** and **research plan** and the abstract for all other prior years. Copies must be attached behind the current year's **research plan** and forms. Each page of prior work must be clearly labeled in the upper right corner with the years (ex. 2020-2021). Retain all previous years' paperwork in case an SRC requests documentation of experimentation conducted in prior years.
4. A copy of the completed Form 7 must be **vertically displayed** at your project.

SCIENTIFIC REVIEW COMMITTEE (SRC)

The purpose of the SRC is to qualify a student researcher to enter the CTSEF. The committees are made up of a group of adults knowledgeable about regulations concerning experimentation in restricted and non-restricted areas. They review and approve experimental procedures to make sure they comply with the Rules and any pertinent laws.

The SRC consists of a minimum of:

- a) a biomedical scientist (Ph.D., M.D., D.V.M., D.D.S., or D.O.)
- b) a science teacher
- c) at least one other member

The SRC examines projects for the following:

- a) evidence of library research
- b) evidence of proper supervision
- c) use of accepted research techniques
- d) completed forms, signature, and dates
- e) appropriate documents and substantial expansion for continuation projects
- f) compliance with the ISEF ethics statement

The SRC **further** examines projects for:

- a) evidence of search for alternatives to animal use
- b) humane treatment of vertebrate animals
- c) compliance with rules and laws governing human and animal research
- d) compliance with rules regarding potentially hazardous biological agents, controlled substances, and hazardous substances and devices

The SRC follows this two-step process:

- 1) **BEFORE EXPERIMENTATION**, the SRC reviews and approves experimental procedures for projects involving Human Participants, nonhuman vertebrates, pathogenic agents, controlled substances, recombinant DNA, and human/animal tissue to make sure that they comply with the Rules and any pertinent laws. Human studies reviewed and approved by a properly constituted IRB must be reviewed by the SRC before beginning research.
- 2) **AFTER EXPERIMENTATION AND SHORTLY BEFORE THE CTSEF**, the SRC reviews and approves those same projects to make sure that students followed the approved **Research Plan** and the Rules and Guidelines.

INSTITUTIONAL REVIEW BOARD (IRB)

An Institutional Review Board (IRB) is a committee that, by federal law, **must evaluate the potential physical or psychological risk of research involving Human Participants**. All proposed human research must be reviewed and approved by a proper IRB before experimentation begins. This includes review of any videos, music, games, surveys, or questionnaires to be used in a project.

An IRB at the local school level or the CTSEF must consist of a minimum of three members. Additional members are recommended to avoid conflict of interest. The IRB should include:

- a) an educator (not the teacher that is serving as the Adult Sponsor),
- b) a school administrator (preferably, a principal or vice principal),
- c) and one or more of the following: a psychologist, psychiatrist, medical doctor, physician's assistant,
or registered nurse or licensed social worker.
- d) When the project concerns behavioral research, the IRB must include a psychologist or psychiatrist. (Federal law 25-CFR-46.)

Due to the federal regulations requiring local community involvement, an IRB should be established at the school level to deal with human research projects. If it is impossible to establish an IRB at each school, the teacher/school should contact the CTSEF IRB for assistance in evaluating human research prior to experimentation.

- 1) Institutional Review Boards (IRBs) exist at federally registered research institutions. For research not performed at one of these facilities, the sponsoring research organization (high school, local, or affiliated fair, etc.) must appoint an IRB to review and approve any proposed research involving Human Participants.
- 2) **An IRB generally makes the final determination of risk. However, if the SRC rules an IRB's decision as inappropriate, thereby placing Human Participants in jeopardy, the SRC may override the IRB's decision and the project may fail to qualify for competition.**
- 3) A school-established IRB must register its members with the CTSEF.
- 4) The chair of the school IRB must attend a workshop sponsored by the CTSEF.
- 5) **If the project is behavioral, a psychologist, psychiatrist, or individual with human behavioral training* must serve on the IRB.**
- 6) **For subjects under 18, student researchers must obtain written informed consent from all subjects and their parent/guardian when more than minimum risk is involved.**
- 7) **Neither the Adult Sponsor, parents, nor the Qualified Scientist who oversees a specific project is permitted to serve on the SRC or IRB reviewing that project. Consequently, neither the Adult Sponsor nor the Qualified Scientist may sign the SRC/IRB portion of Approval Form (1B). This eliminates conflict of interest.**

*Human behavioral training (i.e., RN must undergo course work plus training in an institutional setting such as a state psychiatric hospital).

CTSEF ADDITIONAL HUMAN PARTICIPANTS GUIDELINES

Pre-collegiate researchers conducting human experiments using movies, video games, videos, music lyrics, surveys, questionnaires, pictures, photographs, drawings, or printed advertisements must adhere to the following guidelines:

1. Movies - limited to these ratings: G, PG, or PG-13. Those movies rated PG-13 must be reviewed and approved by the parents of subjects under 18 years old. The researcher must present parents' documentation of the viewing and written approval for each subject.
2. Video games - can only include the following industry rated categories: EC, E, and E10+. Those video games rated E10+ must be reviewed and approved by parents of subjects under 18 years old. The researcher must present parents' documentation of the viewing and written approval for each subject.
3. Videos - all other videos not included in the categories listed above under #1 or #2, must be reviewed by the CTSEF IRB before approval. This includes music videos, home videos, YouTube videos, etc. NO EXCEPTIONS!
4. Music - recorded or printed lyrics must be reviewed by the CTSEF IRB and approved. Lyrics with references to profanity, sexuality/sexual behavior, violence, alcohol or drug use, weapons, or human injury or death, will not be approved.
5. Visual images - pictures, photographs, drawings, advertisements, etc., must be reviewed and approved by the CTSEF IRB before experimentation may begin. Any visual images portraying sexual behavior, violence, alcohol or drug use, weapons, human injury or death, or derogatory behaviors will not be approved.
6. Surveys and questionnaires - copies must be submitted to the CTSEF IRB for review and approval. Any that expose the subject to emotionally distressing questions, materials or activities will not be approved.
7. Ingestion Projects - a detailed explanation is required to explain why the participant is to ingest the item. All safety procedures must be included with the explanation.

The CTSEF IRB will make every effort to help you develop an acceptable project. However, research designs that propose one or more of the above risk categories may be difficult or impossible to get approved.

All IRB projects MUST be approved by the CTSEF Review committee before any experimentation may begin.

DISPLAY AND SAFETY REGULATIONS

The following regulations must be adhered to when a student exhibits a project at CTSEF. All projects must adhere to the Display and Safety requirements of the fair in which they compete to qualify for participation in CTSEF. Knowledge of these requirements is the responsibility of the student and adult sponsor.

Display Regulations

Maximum Size of Project

Depth (front to back): 30 inches or 76 centimeters
Width (side to side): 48 inches or 122 centimeters
Height (floor to top): 108 inches or 274 centimeters

All project materials and support mechanisms must fit within the project dimensions (including table covers).

Fair-provided tables at CTSEF will not exceed a height of 36 inches.

Forms Required to be Visible and Vertically Displayed at the Project

The placement of the required forms may include the front edge of the table, the display board, or in a free-standing acrylic frame placed on the table top.

Forms Required at all Projects

An original Official Abstract and Certification as approved by the CTSEF SRC.

Upon SRC approval, the Official Abstract will be used and displayed.

1. The abstract must be the official Abstract and embossed/ stamped by the CTSEF SRC.
2. No other format or version of your approved Abstract & Certification will be allowed for any purpose at CTSEF. Abstract handouts to judges and to the public are limited to UNALTERED photocopies of the official abstract and certification.
3. The term "abstract" may NOT be used as a title or reference for any information on a display or materials at the project, except as part of displaying the official stamped/ embossed abstract.
4. It is the recommendation of the D&S Committee to NOT include the word "abstract" nor the abstract itself when preparing backboards or posters prior to the fair. However, it is reasonable to leave a blank space (8 ½" x 11") on the backboard/poster to facilitate the addition of the official abstract. Keep in mind this document can also be displayed vertically on the front edge of the table or in a free-standing acrylic frame.
5. Project Set-up Approval Form
 - a. This form documents the project as approved by the SRC and is used to document the D&S Committee's review process and final approval.

- b. This form must be signed by the D&S Committee member at the time of inspection.

Additional Forms required (when applicable)

1. Regulated Research Institutional/Industrial Setting Form (1C)

If work was conducted in a regulated research institution, industrial setting, or any work site other than home, school, or field at any time during the current CTSEF project year, the Regulated Research Institutional/Industrial Setting Form 1C must be completed and vertically displayed at the project booth.

Additional Forms required (when applicable)

1. Regulated Research Institutional/Industrial Setting Form (1C)

- a. If work was conducted in a regulated research institution, industrial setting, or any work site other than home, school, or field at any time during the current CTSEF project year, the Regulated Research Institutional/Industrial Setting.
 - b. The information provided by the mentor on Form 1C may be referenced to confirm that the information provided on the project board is that of the finalist. Only minimal reference to a mentor's or another researcher's work is allowable and must only reflect background information or be used to clarify differences between finalist's and others' work
2. Continuation/Research Progression Projects Form (7)
 - a. If a study is a continuation/research progression, the Continuation / Research Progression Projects Form 7 must be completed and vertically displayed at the project booth.
 - b. The display board and abstract must reflect only the current year's work. The project title displayed may mention years of continuing research (for example, "Year Two of an Ongoing Study").
 - c. Reference to past work on the display board must be limited to summative past conclusory data and its comparison to the current year data set. No raw data from previous years may be publicly displayed; however, it may be included in the student research notebooks and/or logbooks if properly labeled.

Forms Required at Project but not Displayed

3. Forms, excluding those listed above, that were required for the SRC approval should not be vertically displayed, but must be available in case asked for by a judge or other CTSEF official. These forms include, but are not limited to, Checklist for Adult Sponsor (1), Student Checklist (1A), Research Plan, Approval Form 1B, and a photograph/video release form.
4. A photograph/video release form signed by the subject is required for visual images of humans (other than the finalist) displayed as part of the project.

Forms NOT to be at the Project Display

5. Completed informed consent/assent forms for a human participant study are NOT to be displayed and should NOT be present at the project display. The student may include a sample (incomplete) form in their logbook or research notebook, but under NO CIRCUMSTANCE should the completed informed consent/assent forms for a human participant be in the Exhibit Hall.

Photograph/Image Display Requirements

6. Any photograph/visual image/chart/table and/or graph is allowed if:
 - a. It is not deemed offensive or inappropriate (which includes images/photographs showing invertebrate or vertebrate animals/humans in surgical, necrotizing, or dissection situations) by the SRC, the D&S Committee.
 - b. It has a credit line of origin ("Photograph taken by..." or "Image taken from..." or "Graph/Chart/Table taken from..."). If all images, etc. displayed were created by the finalist or are from the same source, one credit line prominently and vertically displayed on the backboard/poster or tabletop is sufficient. ALL IMAGES MUST BE PROPERLY CITED. This includes background graphics, photographs and/or visual depictions of the finalist or photographs and/or visual depictions of others for which a signed photo/video release form is in a notebook at the project booth. These signed release forms must be available upon request during the inspection process, but may not be displayed.
 - a. Sample release text: "I consent to the use of visual images (photos, videos, etc.) involving my participation/my child's participation in this research."

2. Finalists using any presentation or demonstration outside of a project board must be prepared to show the entire presentation to the D&S Inspectors before the project is approved. All aforementioned rules apply to this presentation and the presentation may not be altered in any way after the final D&S inspection. Examples of presentations that require approval include, but are not limited to PowerPoint, Prezi, Keynote, software program/simulation and other images and/or graphics displayed on a computer screen or other non-print delivery method.

Items/Materials Not Allowed on Display

1. Any information on the project display or items that are acknowledgments, self-promotions, or external endorsements.
 - a. The use of logos, including known commercial brands, institutional crests or trademarks, flags unless integral to the project and approved by SRC via inclusion in Abstract and Certification.
 - b. Personalized graphic/logos that are developed to indicate a commercial purpose or viability of an established or proposed business associated with the project.
 - c. Any reference to an institution or mentor that supported the finalist's research except as provided in the official CTSEF paperwork, most notably Form 1C. Published research papers may only be present within a lab notebook.
 - d. Any reference to patent status of the project.
 - e. Any items intended for distribution such as disks, CDs, flash drives, brochures, booklets, endorsements, give-away items, business cards, printed materials, or food items designed to be distributed to judges or the public. Once again, handouts to judges and to the public are limited to UNALTERED photocopies of the official abstract.
2. Any awards or medals.
3. Postal addresses, WWW, email, and/or social media addresses, QR codes, telephone and/or fax numbers of a project or finalist. Note: The only personal information that is permissible to include on the display is information that is also included on the Official Abstract and Certification (Finalist Name, School, City, State). Information regarding finalist's age and grade are not permitted.
4. Active Internet or email connections as part of displaying or operating the project at CTSEF.
5. Any changes, modifications, or additions to projects including any attempt to uncover,

replenish or return removed language or items after the approval by the D&S Committee and the SRC has been received is prohibited.

- a. D&S inspections may include recording photographic evidence of the approved project display.
- b. Students who do not adhere the CTSEF Project Set-up Approval Form regarding this regulation may fail to qualify for competition.
- c. I/we understand that the initial D&S

Inspection has been completed, but that additional reviews occur and that I/we should check back regularly. I/we further understand that returning items that have been removed by the SRC or D&S and/or adding items that are not permitted after final clearance are grounds for failing to qualify for competition and/or forfeiture of all awards received.

Safety Regulations

Not Allowed at Project

Note: In the case in which a project includes an item that is prohibited from display, please consider taking photographs and/or documenting the significance of the prohibited item through video.

1. Living organisms, including plants
2. Glass
3. Soil, sand, rock, cement, and/or waste samples, even permanently encased in a slab of acrylic
4. Taxidermy specimens or parts
5. Preserved vertebrate or invertebrate animals
6. Human or animal food
7. Human/animal parts or body fluids (for example: blood, urine)
8. Plant materials (living, dead, or preserved) that are in their raw, unprocessed, or non-manufactured state
9. All chemicals including water. Absolutely no liquids can be utilized in the Project Display
10. All hazardous substances or devices (Examples: poisons, drugs, firearms, weapons, ammunition, reloading devices, granules or powders, grease/oil, and sublimating solids such as dry ice)
11. Items that may have contained or been in contact with hazardous chemicals (Exception: Item may be permitted if professionally cleaned and documentation for such cleaning is available). Filters (including microbial) may not be displayed unless the Display & Safety Committee can reasonably determine that the device was cleaned or was never used (please include receipts in your notebooks and/or logbooks)
12. Sharp items (for example, syringes, needles, pipettes, knives)
13. Flames and highly flammable materials
14. Batteries with open-top cells or wet cells
15. Drones or any flight-capable apparatus unless the propulsion power source removed.
16. 3D Printers unless the power source is removed.
17. Inadequately insulated apparatus capable of producing dangerous temperatures are not permitted
18. Any apparatus with belts, pulleys, chains, or moving parts with tension or pinch points that are not appropriately shielded

19. Any display items that are deemed distracting (i.e., sounds, lights, odors, etc.)
20. Any apparatus or project material deemed unsafe by the SRC or the D&S Committee.

Electrical Regulations

1. Electrical power supplied to the project is 120 or 220 Volt, AC, single phase, 60 Hz. No multi-phase will be available or shall be used. Maximum circuit amperage/wattage available is determined by the electrical circuit capacities of the exhibit hall and may be adjusted on-site by the D&S Committee. For all electrical regulations, "120 Volt AC" or "220 Volt AC" is intended to encompass the corresponding range of voltage as supplied by the facility in which CTSEF is being held.
2. Electrical devices must be protectively enclosed. Any enclosure must be non-combustible. All external non-current carrying metal parts must be grounded.
3. Energized wiring, switches, and metal parts must have adequate insulation and over-current safety devices (such as fuses) and must be inaccessible to anyone other than the finalist. Exposed electrical equipment or metal that may be energized must be shielded with a non-conducting material or with a grounded metal box to prevent accidental contact.
4. Decorative lighting or illumination is discouraged. If used, lighting must be as low a voltage as possible and must be LED lighting that does not generate heat. Incandescent and fluorescent light bulbs are prohibited. When student is not at the exhibit, all electrical power must be disconnected, or power bars must be switched off (Exception: during pre-judging audio visual displays may be available.)
5. An insulating grommet is required at the point where any wire or cable enters any enclosure.
6. No exposed live circuits over 36 volts are allowed.
7. There must be an accessible, clearly visible on/off switch or other means of quickly disconnecting from the 120 or 220-Volt power source.

Laser/Laser Pointer Regulations

Any Class 1, Class 2, Class 3A, or Class 3R lasers are allowed to be used responsibly. No other lasers may be used or displayed.

1. Laser beams may not pass through magnifying optics such as microscopes and telescopes. Lasers must be labeled by the manufacturer so that power output can be inspected. Lasers without labels will NOT be permitted.
2. Lasers must be labeled by the manufacturer so that power output can be inspected. Lasers without labels will NOT be permitted.
3. Handheld lasers are NOT permitted.
4. Lasers will be confiscated with no warning if not used in a safe manner.

ENTRY RULES

- 1) All projects must be entered online in STEM Wizard to compete at the CTSEF.
- 2) No project that uses forms different from the CTSEF website will be accepted. The current year forms must be used.
- 3) Each exhibitor must furnish all information requested on STEM Wizard. Failure to do so will result in an application not being processed for entry.
- 4) All approved forms, a copy of the abstract, and a \$12 entry fee per student must be included with the official entry (payment of entry fees can be modified).
- 5) The abstract must be a one-page summary of the current year's work only. It must describe research conducted by the student, not by adult supervisors. The abstract can have a maximum of 250 words.
- 6) Students with projects that are a continuation of previous year's research must submit all prior year's abstracts and research plans, properly labeled, at entry deadline.
- 7) Entry paperwork must be submitted through STEM Wizard by the entry deadline on **Friday, February 7, 2025**. LATE APPLICANTS WILL NOT BE ACCEPTED FOR ENTRY.
- 8) Carefully check the entry form for accuracy before submitting. No last-minute changes will be made on the day of the fair if inaccurate information was given.
- 9) Applications for the Baylor University Scholarship Award and the Bryce C. Brown Award for the Most Promising Young Scientist must be submitted to the CTSEF office by the deadline.
- 10) Entry fees will not be refunded if a student fails to attend the CTSEF. No exceptions.

JUDGING RULES

- 1) The senior division (grades 9-12) will be judged separately from the junior division (grades 6-8).
- 2) During judging the exhibition area will be closed to all except student entrants, judges, and CTSEF officials.
- 3) All exhibitors must be present and remain with their exhibits during the regular judging time. Students may not leave their exhibits (except to go to the restroom) until released by CTSEF officials. Plan on a late night.
- 4) All exhibits must be approved by the Scientific Review Committee, and the Display and Safety Committee. A signed approval form must be displayed at the exhibit before it will be judged.
- 5) In any case involving a question of judging, eligibility, or any other aspect of the Central Texas Science and Engineering Fair, the decision of the CTSEF Director and the Scientific Review Committee will be final.

STUDENT CHECKLIST

1. **READ** ISEF Rules and Guidelines thoroughly and carefully, paying special attention to the sections entitled: Student Guidelines, Rules for All Participants, Display and Safety Regulations, and Entry Rules.
2. Using the Student Guidelines section as a roadmap, start to **THINK** about research that may interest you. Talk to your teacher/adult sponsor concerning your project. Remember that all projects need approval before experimentation can begin.
3. **SUBMIT** all required paperwork by pre-approval deadline online through STEM Wizard at: www.ctsef.org
 - **Waiver and Release of Liability Forms** must be completed for CTSEF to process your paperwork.
 - **Form 1** – Checklist for Adult Sponsor.
 - **Form 1A** – Student Checklist. Remember that experimentation cannot begin until all forms have been read and approved by CTSEF.
 - **Research Plan** – This document will include your problem statement, your hypothesis, your materials list, your procedure for testing the hypothesis, and the sources of your research (bibliography). Remember, be consistent with the format you choose for your bibliography and write your procedure in step-by-step format so it can be repeated by someone else.
 - **Form 1B** – Approval Form. This form requires several signatures. Be certain that you allow enough time to complete your research!
 - There may be various **other forms** that must be completed and signed as required by your particular type of project. Refer to the international rules book to determine your type of project and the necessary forms needed to satisfy the requirements.
 - \$5 filing fee per student for pre-approval review. For all research projects, the research plan and all applicable forms must be completed online and the \$5 filing fee sent to the CTSEF office for each student before the pre-approval deadline
 - **All IRB** projects (those involving Human Participants) **might** require an interview. **Interviews will only be held as requested by the IRB committee chairperson and will not be charged an additional fee.**
 - \$12 per project for optional **regional SRC interview**. This fee is **optional** and applies only if a student wishes to have a regional SRC personal interview for his/her proposed research.
4. **CORRECT** deficiencies and **RESUBMIT** by correction deadline: (See Important Dates and Deadlines) or as soon as corrections are made.
 - Suggestions and/or corrections will be returned to you with your paperwork online.
 - The student must correct the deficiencies and the teacher/sponsor must check each correction. Deficiencies require that paperwork be returned online until online process is complete by CTSEF.

- A student's project is approved to begin experimentation when the CTSEF committee chairperson has signed off on STEM Wizard.
5. **PERFORM YOUR EXPERIMENT AND GATHER DATA** according to the approved procedure in your research plan.
 6. **SUBMIT ENTRY FORM AND OTHER REQUIRED FORMS BY ENTRY DEADLINE**
(See Important Dates and Deadlines)
 - Continuation of previous year's(s') research must include all previous dated abstracts and research plans as attachments, properly labeled.
 - No last-minute changes will be made at the fair for inaccurate information submitted on forms.
 - LATE APPLICANTS WILL NOT BE ACCEPTED FOR ENTRY!
 - **Entry fees will not be refunded** if a student fails to attend the CTSEF. No exceptions.
 - \$12 entry fee per student.
 7. **REGISTER** at the regional fair site at announced time and date.
 8. Your **Project Data/Research Notebook** must be at your project.
 9. **PLAN** for late judging. Dismissal of students should be no later than 9:30 p.m.
 10. **ATTEND** the Awards Ceremony the next morning. (Awards ceremony times may change.)

STUDENT GUIDELINES FOR SCIENCE FAIR PROJECTS

Science Research and the Process of Science

Research is the process by which people discover or create new knowledge about the world in which they live. The Affiliated Fairs are research (data) driven. Students design research projects that provide quantitative data through experimentation followed by analysis and application of the data. Projects that are demonstration “library” research or informational projects, “explanation” models or kit building are not appropriate for research-based science fairs. When choosing your topic, give careful thought to how your research might enhance the world and its inhabitants.

Questioning is probably the most important part of scientific creativity and is often followed by an “if...then” statement. Students are encouraged to design “controlled” experiments, ones that allow them to set up a standard and then change only one variable at a time to see how that variable might affect the original condition tested as the standard. Thus, questioning usually leads to experiments or observations.

Good scientists, both young and old, use a process to study what they see in the world. The process has been referred as the “Scientific Method” or more recently as the “Inquiry Cycle.” From the following stages, you should be able to produce a superior scientific experiment:

- 1) Be curious, choose a limited subject, ask a question; identify or originate/define a problem. It is important that this question be a ‘testable’ question – one in which data is taken and used to find the answer. A testable question can further be identified as one in which one or more variables can be identified and tested to see the impact of that variable on the original set of conditions. The question should not merely be ‘information’ question where the answer is obtainable through literature research.
- 2) Review published materials related to your problem or question. This is called background research.
- 3) Evaluate possible solutions and guess why you think it will happen (hypothesis).
- 4) Experimental design (procedure). In designing the experiment, it is critical that only one variable – a condition that may affect the results of the experiment – is changed at a time. This makes the experiment a ‘controlled’ experiment.
- 5) Challenge and test your hypothesis through your procedure of experimentation (data collection) and analysis of your data. Use graphs to help see patterns in the data.
- 6) Draw conclusions based on empirical evidence from the experiment.
- 7) Prepare your report and exhibit.
- 8) Review and discuss the findings with peer group/ professional scientists
- 9) New question(s) may arise from your discussions.

This sets the stage for another research project as new questions are raised from others and the process repeats itself. The hypothesis often changes during the course of the experiment. Supporting or not supporting your hypothesis is secondary to what is learned and discovered during the research.

Students should learn to be skeptical of all research results, especially their own. A good experiment may or may not answer the questions asked, but almost always leads to fresh questions requiring new experiments or observations. The final hypothesis is often developed after one has run a number of preliminary experiments, analyzed a body of results, and reached a tentative conclusion.

All projects need approval prior to experimentation. All projects require the **Waiver and Release of Liability, Checklist for Adult Sponsor, Student Checklist (1A), Research Plan, Approval Form (1B)**, and an **abstract**. To confirm paperwork needed prior to experimentation, refer the ISEF Rules and Guideline www.societyforscience.org/isef.

Non-Inquiry Based Research

Not all areas of study are best served by scientific methods-based research. Because engineers, inventors, mathematicians, theoretical physicists, and computer programmers have different objectives than those of other scientists, they follow a different process in their work. The process and that they use to answer a question or solve a problem is different depending on their area of study. Each one uses their own criteria to arrive at a solution.

Engineering Projects

“Scientists try to understand how nature works; engineers create things that never were.” An engineering project should state the engineering goals, the development process, and the evaluation of improvements. Engineering projects may include the following:

- 1) Define a need or “How can I make this better?”
- 2) Develop or establish design criteria (could be more than one)
- 3) Do background research and search the literature to see what has already been done or what products already exist that fill a similar need. What make them good and what makes them weak?
- 4) Prepare preliminary designs and a materials list. Consider costs, manufacturing, and user requirements.
- 5) Build and test a prototype of your best design. Consider reliability, repair, and servicing.
- 6) Retest and redesign as necessary.
- 7) Present results.

Computer Science Projects

These often involve creating and writing new algorithms to solve a problem or improve on an existing algorithm. Simulations, models or ‘virtual reality’ are other areas on which to conduct research.

Mathematics Projects

These involve proofs, solving equations, etc. Math is the language of science and is used to explain existing phenomena or prove new concepts and ideas.

Theoretical Projects

These projects may involve a thought experiment, development of new theories and explanations, concept formation or designing a mathematical model.

Getting Started

- 1) **Pick Your Topic.** Get an idea of what you want to study. Ideas might come from hobbies or problems you see that need solutions. Due to limited time and resources, you may want to study only one or two specific events.
- 2) **Research Your Topic.** Go to the library or internet and learn everything you can on your topic. Observe related events. Gather existing information your topic. Look for unexplained or unexpected results. Also, talk to professionals in the field, write or email the companies for specific information, and obtain or construct needed equipment.
- 3) **Organize.** Organize everything you have learned about your topic. At this point you should narrow your hypothesis by focusing on a particular idea. Your library research should help you.
- 4) **Make a Timetable.** Choose a topic that not only interests you, but also can be done in the amount of time you have. Use a calendar to identify important dates. Leave time to fill out the forms and to review the Research Plan with your Sponsor. Certain projects require more time because they need prior SRC or IRB approval. Allow plenty of time to experiment and collect data – even simple experiments do not always go as you might expect the first time or even the second time. Also leave time to write a paper and put together an exhibit.
- 5) **Plan Your Experiments.** Once you have a feasible project idea, write a research plan. This plan should explain how you will do your experiments and exactly what it will involve. All students participating in the CTSEF are required to complete the **Waiver and Release of Liability, Checklist for Adult Sponsor, Student Checklist (1A), Research Plan, and Approval Form (1B).**
- 6) **Consult Your Teacher or Adult Sponsor.** You are required to discuss your research plan with a Teacher or an Adult Sponsor and obtain a signature of approval. In reviewing **Student Checklist (1A) with Research Plan**, your Sponsor should determine if additional forms and/or IRB/SRC prior approval is needed.
- 7) **Conduct Your Experiments.** Give careful thought to experimental design. During experimentation, keep detailed notes of every experiment, measurement, and observation. Do not rely on your memory. Remember

to change only one variable at a time when experimenting, and make sure to include control experiments in which none of the variables are changed. Make sure you include sufficient numbers of test subjects in both control and experimental groups. A group must have five or more subjects to be statistically valid.

- 8) **Analyze Your Results:** When you complete your experiments, examine and organize your findings. Use appropriate graphs to make ‘pictures’ of your data. Identify patterns from the graphs. This will help you answer your testable question. Did your experiments give you the expected results? Why or why not? Was your experiment performed with the exact same steps each time? Are there other explanations that you had not considered or observed? Were there experimental errors in your data taking, experimental design or observations? Remember, that understanding errors is a key skill scientists must develop. In addition, reporting that a suspected variable did not change the results can be valuable information. That is just as much a ‘discovery’ as if there was some change due to the variable. In addition, statistically analyze your data using the statistics that you can understand and explain their meaning.
- 9) **Draw Conclusions:** Did the variable(s) tested cause a change when compared to the standard you are using? What patterns do you see from your graph analysis that exists between your variables? Which variables are important? Did you collect enough data? Do you need to conduct more experimentation? Keep an open mind – never alter results to fit a theory. If your results do not support your hypothesis, that’s ok and in some cases good! Try to explain why you obtained different results than your literature research predicted for you. Were there sources of error that may have caused these differences? If so, identify them. Even if the results do differ, you still have accomplished successful scientific research because you have taken a question and attempted to discover the answer through quantitative testing. This is the way knowledge is obtained in the world of science. Think of practical applications that can be made from this research. How could this project be used in the real world? Finally, explain how you would improve the experiment and what would you do differently.

Elements of a Successful Project

1) PROJECT DATA BOOK (REQUIRED)

A project data book is your most treasured piece of work. Accurate and detailed notes make a logical and winning project. Good notes show consistency and thoroughness to the judges and will help you when writing your research paper. Data tables are also helpful. They may be a little “messy” but be sure the quantitative data recorded is accurate and that units are included in the data tables. Make sure you date each entry.

2) RESEARCH PAPER (OPTIONAL)

A research paper can be prepared and available along with a project data book, and any necessary forms or relevant written materials. A research paper helps organize data as well as thoughts. A good paper includes the following sections:

- a) **Title Page.** Title of your project, division, and classification.
- b) **Table of Contents.** Include a page number for the beginning of each section.
- c) **Introduction.** The introduction sets the scene for your report. The introduction includes your hypothesis, an explanation of what prompted your research, and what you hoped to achieve.
- d) **Materials & Methods (Experiment).** Describe in detail the methodology used to collect your data or make your observations. Your report should be detailed enough so that someone would be able to repeat the experiment from the information in your paper. Include detailed photographs or drawings of self-designed equipment. Only include this year's work.
- e) **Discussion.** The discussion is the essence of your paper. The results and conclusions should flow smoothly and logically from your data. Be thorough. Allow your readers to see your train of thought, letting them know exactly what you did. Compare your results with theoretical values, published data, commonly held beliefs, and/or expected results. Include a discussion of possible errors. How did the data vary between repeated observations of similar events? How were your results affected by uncontrolled events? What would you do differently if you repeated this project? What other experiments should be conducted?
- f) **Conclusion.** Briefly summarize your results. Be specific; do not generalize. Never introduce anything in the conclusion that has not already been discussed.
- g) **Acknowledgments.** You should always credit those who assisted you, including individuals, businesses, and educational or research institutions. Identify any financial support or material donations received, but do not put on display board.
- h) **References/Bibliography:** Your reference list should include any documentation that is not your own (i.e., books, journal articles, websites, etc.). See an appropriate reference in your discipline for format.

For instance, **APA style:**

- 1) **Journal article, one author –**
Bekerian, D.D. (1993), In Search of the Typical Eyewitness. *American Psychologist*, 48. 574-576.
- 2) **Reference to an entire book –**
Cone, J.D., & Forster, S.L. (1993). *Dissertations and Theses from Start to Finish: Psychology and Related Fields*. Washington, DC: American Psychological Association.

Below MLA Format. Bibliography is alphabetical and not numbered. First line is at the margin and the second line of same reference is indented.

Article from a magazine
SPIRAL STRUCTURE, DUST CLOUDS, AND STAR FORMATIONS. Frank H. Shu in *American Scientist*, Vol. 61, pages 524-536; 1973.

Book with an author
THE LARGE-SCALE STRUCTURE OF THE UNIVERSE. J.P.E. Peebles. Princeton University Press, 1980.

Book with an editor
INTERSTELLAR MOLECULES. Edited by B.H. Andrew. D. Reidel Publishing Company, 1980.

Online website
Planning for College and Academic Planning. The College Board. 7 June 2000.
<http://www.collegeboard.org/features/parentqd/html/academic.html>

3) ABSTRACT

After finishing research and experimentation, you are required to write a (maximum) 250-word, one-page abstract. An abstract should include the (a) purpose of the experiment, (b) procedures used, (c) data, and (d) conclusions. It also may include any possible research applications. Only minimal reference to previous work may be included. The abstract should focus on work done since the last fair and should not include: a) acknowledgments, or b) work on procedures done by the mentor. The abstract must be vertically displayed on the project board or in a frame in front of the project board. A copy of your abstract must be included with your paperwork submitted for entry and must be on ISEF required form. The only abstract allowed anywhere at a project is the official abstract (ISEF). The term "abstract" may not be used as a title or reference for any information on an entry display or on materials at the project except as part of the official abstract.

4) VISUAL DISPLAY

You want to attract and inform. Make it easy for interested spectators and judges to assess your study and the results you have obtained. Make the most of your space using clear and concise displays. Make headings stand out, and draw graphs and diagrams clearly and label them correctly. Leave your glassware and chemicals at home. Please make sure to reference the Display and Safety Rules in this book; this information is also available on the Society for Science & the Public website at:
www.societyforscience.org/isef

Helpful Hints for Display:

- a) Make sure the display reflects the current year's work only.
- b) **A Good Title.** Your title is an extremely important attention-grabber. A good title should simply and accurately present your research. The title should make the casual observer want to know more.
- c) **Take Photographs.** Many projects involve elements that may not be safely exhibited at the fair but are an important part of the project. You might want to take photographs of important parts/phases of your experiment to use in your display. Photographs or other visual images of human test subjects must have informed consent (Form 4) please read the International Rules (ISEF guidelines 2021).
- d) **Be Organized.** Make sure your display is logically presented and easy to read. A glance should permit anyone (particularly the judges) to locate quickly the title, experiments, results, and conclusions. When you arrange your display, imagine that you are seeing it for the first time.
- e) **Eye-Catching.** Make your display stand out. Use neat, colorful headings, charts, and graphs to present your project. Home-built equipment, construction paper, and colored markers are excellent for project displays. Pay special attention to the labeling of graphs, charts, diagrams, and tables. Each item must have a descriptive title. Anyone should be able to understand the visuals without further explanation.
- f) **Correctly Presented and Well-Constructed.** Be sure to adhere to the size limitations and safety rules when preparing your display. Display all required forms for your project. Make sure your display is sturdy, as it will need to remain intact for quite a while. Do not hesitate to ask for advice from adults as needed.

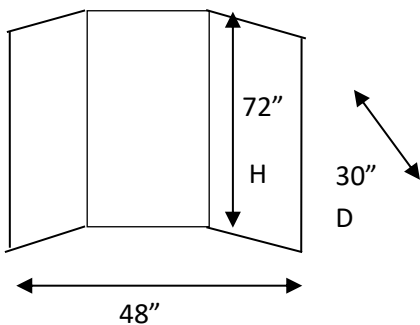

30" deep
48" wide
72" high
(does not include table height)

Judges

- 1) Judges evaluate and focus on 1) what the student did in the current year; 2) how well a student followed the scientific methodologies; 3) the detail and accuracy of research as documented in the data book; and 4) whether experimental procedures were used in the best possible way.

- 2) Judges look for well thought-out research. They look at how significant your project is in its field, as well as how thorough you were. Did you leave something out? Did you start with four experiments and finish only three?
- 3) Judges applaud those students who can speak freely and confidently about their work. They are not interested in memorized speeches – they simply want to TALK with you about your research to see if you have a good grasp of your project from start to finish. Besides asking the obvious questions, judges often ask questions to test your insight into your projects such as “What was your role?”, “What didn’t you do?” and “What would be your next step?”

JUDGING CRITERIA (points)

	<u>Individual</u>	<u>Team</u>
Creative Ability	30	25
Scientific Thought and Engineering Goals	30	25
Thoroughness	15	12
Skill	15	12
Clarity	10	10
Teamwork	--	16

Patent and Copyright Information

You may want to consider applying for a patent or copyright if you want to protect your work. You can contact the Office of Public Affairs, U.S. Patent Office, at 703/305-8341 for Patent information or the Library of Congress at 202/707-3000 for copyright information.

Important Student Requirement

- 1) Each student may enter only one project, which covers research done over a maximum continuous 12-month period between January 2024 and May 2025.
- 2) Students may compete in only one ISEF Affiliated Fair, except when proceeding to a state/national fair affiliated with the ISEF from an affiliated regional fair.
- 3) Any student in grades 9-12 or equivalent is eligible, none of whom has reached age 21 on or before May 1 preceding the ISEF.
- 4) Any student in grades 6 -12 are eligible to compete in the CTSEF if approved by the CTSEF committee and qualified as a top winner placing 1st, 2nd, or 3rd at their local fair.
- 5) The student researcher is responsible for all aspects of the research project including enlisting the aid of any needed supervisory adults (Adult Sponsor, Qualified Scientist, etc.), obtaining necessary approvals (SRC, IRB, etc.), following the Rules & Guidelines of the ISEF and the CTSEF, and doing the experimentation, engineering, data analysis, etc. involved in the project
- 6) Scientific fraud and misconduct are not condoned at any level of research or competition. Such practices include plagiarism, forgery, use or presentation of other researcher's work as one's own and fabrication of data. Fraudulent projects will fail to qualify for competition in affiliated fairs or the ISEF.

GUIDELINES FOR HYPOTHESES

RESEARCH HYPOTHESIS

A research hypothesis is the expected outcome of an experiment. It is a simple statement of what the researcher expects to find upon conducting a study. It is a specific and testable prediction and must have some variables.

A researcher must consider all the possibilities about a relationship between variables that he/she has identified in his/her project. Using his/her background knowledge of the topic, the researcher should choose which prediction he/she thinks will most likely occur. It is usually a declarative statement, but an "If...then..." type of statement may also be used to express a hypothesis.

Examples:

A student wants to test whether a plant grows better in sunlight or artificial light. If s/he expects the plants to grow better in sunlight, his/her hypothesis might state:

"Plants exposed to sunlight will grow better than plants exposed to artificial light."

OR

A student wants to examine fecal coliform pollution in undisturbed and disturbed sediments in a local creek. His/her hypothesis might state:

"If the sediment in Blackwater Creek is disturbed, then the fecal coliform concentration in the water will be higher."

NULL HYPOTHESIS

A null hypothesis is a statement of what the researcher expects NOT to find. It is typically a hypothesis of "no difference." It is often the reverse of what she/he believes; it is put forward to allow the data to contradict it. The researcher never accepts the null hypothesis. The researcher's goal is to reject or fail to reject the null hypothesis through experimentation.

Examples:

A student wants to test the effect of increased carbon dioxide levels in the environment on plant growth. If s/he expects increased levels of CO₂ to result in more rapid plant growth, his/her null hypothesis might state:

"Increased levels of CO₂ in the environment will not result in more rapid plant growth."

OR

A student wants to conduct an experiment to see if starfish that are treated with a growth hormone will show a higher regeneration rate than starfish that are not treated. S/he randomly assigns 11 starfish each with one arm missing to one of two groups. The treatment group (5 subjects) receives the growth hormone and the control group (6 subjects) does not. His/her null hypothesis might state:

"There is no difference in the regeneration rates between the treatment groups receiving a growth hormone and the control group not receiving a growth hormone."

ADULTS INVOLVED IN A SCIENCE PROJECT

The Adult Sponsor (AS)

An Adult Sponsor may be a teacher, parent, university professor, or scientist in whose lab the student is working. This individual must have a solid background in science and should have close contact with the student during the course of the project.

The Adult Sponsor is ultimately responsible not only for the health and safety of the student conducting the research, but also for the humans or animals used as subjects. The Adult Sponsor must review the Checklist for Adult Sponsor (1), the student's Checklist (1A) and Research Plan to make sure that:

- a) experimentation is done within local, state, and federal laws, and the CTSEF Rules.
- b) forms are completed by other adults involved in approving or supervising any part of the experiment.
- c) criteria for the qualified scientist adhere to those set forth in the Guidelines for the Qualified Scientist.

The Adult Sponsor must be familiar with the regulations that govern potentially dangerous research as they apply to a specific student project. These may include chemical and equipment usage, experimental techniques, research involving human or nonhuman animals, and cell cultures, microorganisms, or animal tissues. The issues must be discussed with the student when completing the Research Plan. Some experiments involve procedures or materials that are regulated by state and federal laws. If not thoroughly familiar with the regulations, the Adult Sponsor should help the student enlist the aid of a Qualified Scientist.

The Adult Sponsor is responsible for ensuring that the student's research is eligible for entry in the CTSEF.

IF QUALIFIED:
AS = QS (Qualified Scientist)
AS = DS (Direct Supervisor)

The Qualified Scientist (QS)

A Qualified Scientist should possess an earned doctoral/professional degree in the biomedical sciences. However, a master's degree with equivalent experience and/or expertise is acceptable when approved by a Scientific Review Committee (SRC). The Qualified Scientist must be thoroughly familiar with the local, state, and federal regulations that govern the student's area of research. The Qualified Scientist and the Adult Sponsor may be the same person, **IF** that person is qualified as outlined above.

A student may work with a Qualified Scientist in another city or state. In this case, the student must work locally with a Direct Supervisor who has been trained in the techniques the student will use.

IF QUALIFIED:
QS = AS (Adult Sponsor)

The Direct Supervisor (DS)

The Direct Supervisor is an adult who supervises a student's experiment. In the case of hazardous substances or devices, a Direct Supervisor is directly responsible for overseeing student experimentation. A Qualified Scientist may or may not be necessary. The Direct Supervisor need not have an advanced degree, but should be thoroughly familiar with the student's project, and must be trained in the student's area of research. The Adult Sponsor may act as the Direct Supervisor.

If a student is experimenting with live vertebrates and the animals are in a situation where their behavior or habitat is influenced by humans, the Direct Supervisor must be knowledgeable about the humane care and handling of the animals.

IF QUALIFIED:
DS = AS (Adult Sponsor)

CATEGORY DESCRIPTIONS

The twenty-one CTSEF and ISEF categories are listed below:

Animal Sciences

- Animal Behavior
- Cellular Studies
- Development
- Ecology
- Genetics
- Nutrition and Growth
- Physiology
- Systematics and Evolution

Behavioral and Social Sciences

- Development
- Cognitive Psychology
- Behavioral Neuroscience
- Sociology and Anthropology

Biochemistry

- Analytical Biochemistry
- General Biochemistry
- Medicinal Biochemistry
- Structural Biochemistry

Biomedical and Health Sciences

- Cell, Organ, and Systems Physiology
- Genetics and Molecular Biology of Disease
- Immunology
- Nutrition and Natural Products
- Pathophysiology

Biomedical Engineering

- Biomaterials and Regenerative Medicine
- Biomechanics
- Biomedical Devices
- Biomedical Imaging
- Cell and Tissue Engineering
- Synthetic Biology

Cellular and Molecular Biology

- Cell Physiology
- Cellular Immunology
- Genetics
- Molecular Biology
- Neurobiology

Chemistry

- Analytical Chemistry
- Computational Chemistry
- Environmental Chemistry
- Inorganic Chemistry
- Materials Chemistry
- Organic Chemistry
- Physical Chemistry

Computational Biology and Bioinformatics

- Computational Biomodelling
- Computational Epidemiology
- Computational Evolutionary Biology
- Computational Neuroscience
- Computational Pharmacology
- Genomics

Earth and Environmental Sciences

- Atmospheric Science
- Climate Science
- Environmental Effects on Ecosystems
- Geosciences
- Water Science

Embedded Systems

- Circuits
- Internet of Things
- Microcontrollers
- Networking and Data Communications
- Optics
- Sensors
- Signal Processing

Energy: Sustainable Materials and Design

- Biological Process and Design
- Solar Process, Materials, and Design
- Energy Storage
- Wind and Water Movement Power Generation
- Hydrogen Generation and Storage
- Thermal Generation and Design
- Triboelectricity and Electrolysis

Engineering Technology: Statics and Dynamics

- Aerospace and Aeronautical Engineering
- Civil Engineering
- Computational Mechanics
- Control Theory
- Ground Vehicle Systems
- Industrial Engineering-Processing
- Mechanical Engineering
- Naval Systems

Environmental Engineering

- Bioremediation
- Land Reclamation
- Pollution Control
- Recycling and Waste Management
- Water Resources Management

Materials Science

- Biomaterials
- Ceramic and Glasses
- Composite Materials
- Computation and Theory
- Electronic, Optical, and Magnetic Materials
- Nanomaterials
- Polymers

Mathematics

- Algebra
- Analysis
- Combinatorics, Graph Theory, and Game Theory
- Geometry and Topology
- Number Theory
- Probability and Statistics

Microbiology

- Antimicrobial and Antibiotics
- Applied Microbiology
- Bacteriology
- Environmental Microbiology
- Microbial Genetics
- Virology

Physics and Astronomy

- Atomic, Molecular, and Optical Physics
- Astronomy and Cosmology
- Biological Physics
- Computational Physics and Astrophysics
- Condensed Matter and Materials
Instrumentation
- Magnetics, Electromagnetics, and Plasmas
- Mechanics
- Nuclear and Particle Physics
- Optics, Lasers, and Masers
- Quantum Computation
- Theoretical Physics

Plant Sciences

- Agriculture and Agronomy
- Ecology
- Genetics and Breeding
- Growth and Development
- Pathology
- Plant Physiology
- Systematics and Evolution

Robotics and Intelligent Machines

- Biomechanics
- Cognitive Systems
- Control Theory
- Machine Learning
- Robot Kinematics

Systems Software

- Algorithms
- Cybersecurity

- Databases
- Human/Machine Interface
- Languages and Operating Systems
- Mobile Apps
- Online Learning

Translational Medical Sciences

- Disease Detection and Diagnosis
- Disease Prevention
- Disease Treatment and Therapies
- Drug Identification and Testing
- Pre-Clinical Studies

INSTRUCTIONS FOR ABSTRACTS

The abstract instructions below are intended for CTSEF participants. Please follow all local CTSEF regional instructions. If you are an ISEF finalist, you will receive further information and will be required to complete this abstract in an online abstract system immediately after winning at the regional or state fair.

The abstract must be written in your own words and will be run through a plagiarism checker.

Writing Requirements

After finishing research and experimentation you are required to write a maximum **250-word, one-page abstract**. The **official abstract form** can be found at: STEM Wizard or www.ctsef.org or www.societyforscience.org. Abstracts may not exceed 250 words and must be typed within the predefined area (5.5" high by 6" wide). Type title (title case required), your first name, middle initial, last name, and school name, city, and state in the first 7.5" of space within the box. Two lines may be used for the title. Teams must include all team member names.

Example: Effects of Marine Engine Exhaust Water on Algae
Mary E. Jones
School, Hometown, State

BE SURE TO ANSWER ALL THE QUESTIONS BY MARKING THE APPROPRIATE BOXES, THEN SIGN AND DATE THE FORM.

The abstract must include (do not label the paragraphs as such):

- Purpose of the experiment
- Basic procedures
- Data summary
- Conclusions

The three common reasons that a student is asked to rewrite the abstract are:

1. Including acknowledgements (that includes naming the research institution and/or mentor with which you were working).
2. Describing research not completed by the student, i.e. a mentor.
3. Describing research done in previous years. Only minimal reference to previous work may be included. Please limit yourself to describing research you have done in the current year.

ALL projects must be submitted online through STEM Wizard.

Once your project is online complete you will need to follow instructions (found on each student profile page) to receive final approval before experimentation may begin.

No student may begin experimentation until he/she has been reviewed and approved. However, initial literature search is not included in this requirement.

www.societyforscience.org/isef
www.ctsef.org

Central Texas Science and Engineering Fair, Inc.

One Bear Place #97154

Waco, TX 76798

254-710-1196

Baylor University

Mayborn Museum Complex

Email: science_fair@baylor.edu

Website: www.ctsef.org